



MWT - 253

The Miyama Nextep plastic encapsulated step irons are designed and manufactured with the latest technology available. The steel core of our step irons is of the Japanese Standard - JIS G3539, and this steel is encapsulated in the highest quality BC-6C polypropylene.

Hand, Eye & Sole Technology

The New Lofty Step System is an internationally patented range of products that incorporates the following features;

POWER GRIP – By using a polypropylene coating, we were able to form the plastic into an ergonomically designed grip. We call it the power grip because when one can get a better grip, one can apply more power, thus improving performance. Human engineering for the hand.

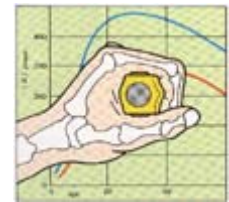

OVERSIZED REFLECTIVE LENSES - are available in red and green for low light working areas. This is engineering for the eye.



SOLE TECHNOLOGY – We have developed features such as the “X” grid pattern on the stepping surface, and in the new Lofty Step System we have improved this sole technology by integrating a slight inward decline to ensure a safe stepping surface. Eye, Hand and Sole Technology.

Models Available – MWT203, MWT253, MWT403 and. Specials upon request.

Applications - Steps are suitable for fitting into precast or existing concrete structures.

Specifications – AS1657-1992 and BS1247- Part 2, 1990

Installation - Please refer to Nextep installation material or consult your nearest Nextep distributor.



An International Leader.....

With over 1000 different models of step irons readily available, plus offering customization for specific size and colour requests, it is no surprise that the Miyama Corporate Group is the largest producer of step irons in the world today. To make a top quality product, you need top quality resources, and Miyama has proven itself over the past 35 years as a world leader in the manufacture of products for underground utilities, ranging from step irons to FRP grating, manhole and access covers. With a daily manufacturing capacity of over 25,000 units, there is no project that is too large, nor too small. For the Australian market, we have designed and tested the following step irons. These units are currently available in safety yellow.

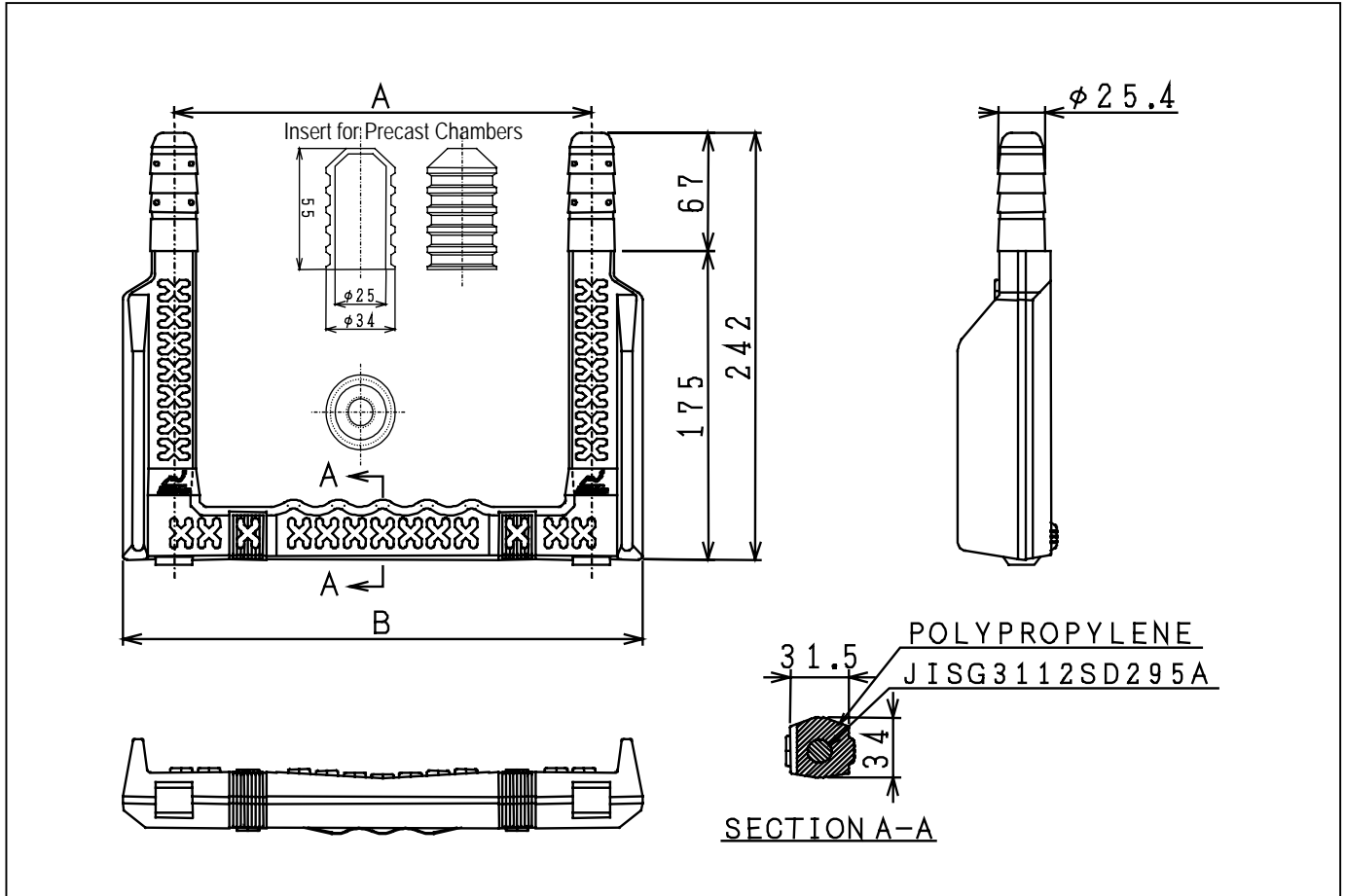

	MWT203	MWT253	MWT403
A	175	225	375
B	230	280	430

All dimensions in millimetres



Nextep Miyama Pty Ltd
 ABN 54 095 373 096
 Po Box 162
 43 Hobart St
 Riverstone NSW 2765
 AUSTRALIA
 Ph +612 9838 3172
 Fx +612 9838 3173
 sales@nextep.net.au