

## 1,500 and 3,000 Litre Oil Traps

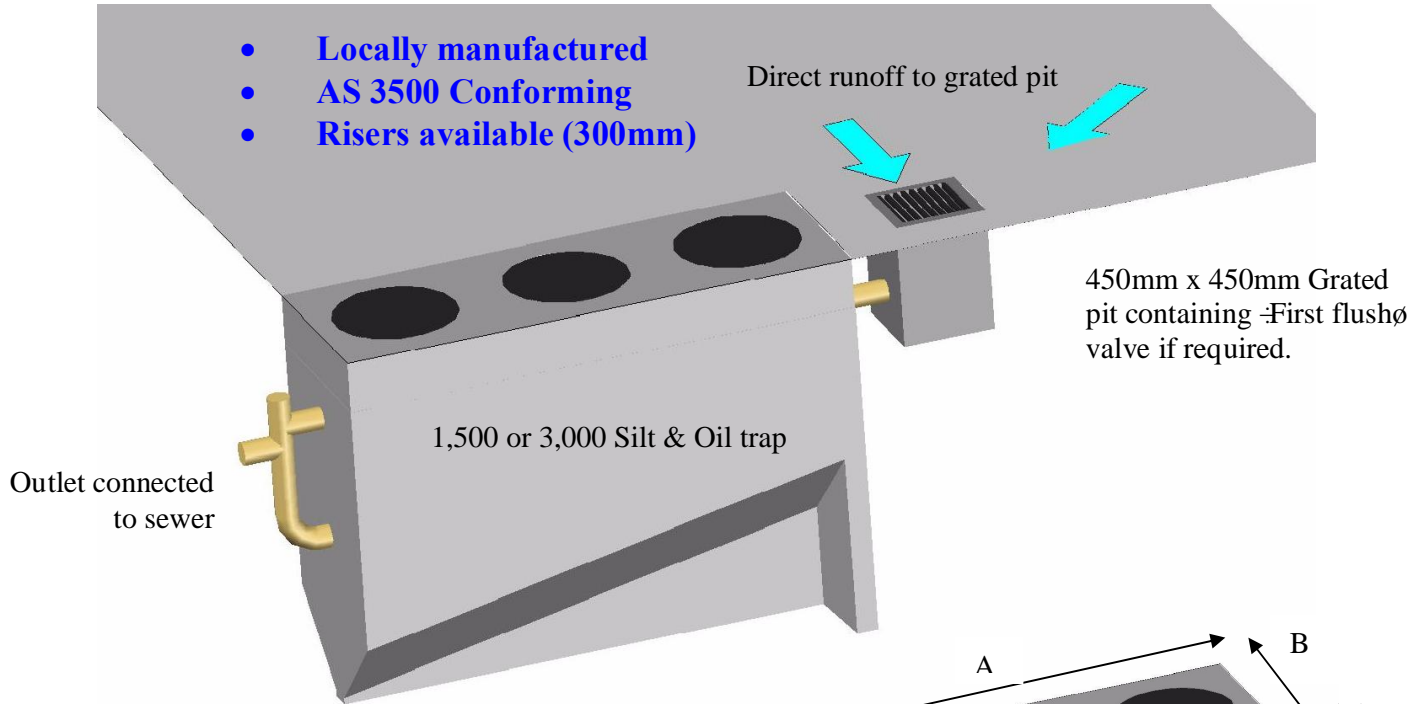

**Hudson Environmental** manufactures two silt & oil trap models, 1,500 litre and 3,000 litre.

Both tanks come as a standard unit with 3 off 600mm Dia clear opening gas tight covers. The external pipe work is supplied by the installation of the junctions only, any additional piping or I.Oø is the responsibility of the plumber.

THESE TANKS MAY FLOAT. We recommend backfilling with concrete be considered in damp conditions or where high water tables may exist.

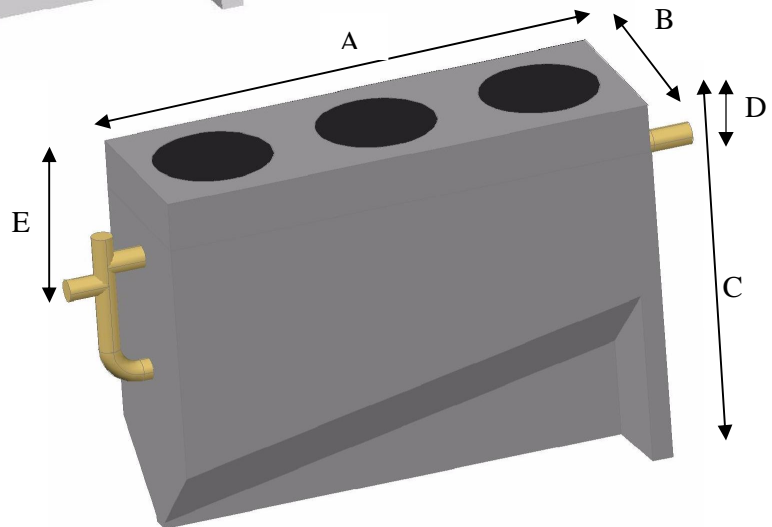

MODEL	CAPACITY	LENGTH 'A'	WIDTH 'B'	HEIGHT 'C'	INLET 'D'	OUTLET 'E'	SURROUND
ST-2-1500	1,500 Litres	2620	885	1900	450	500	Light Duty 250mm Heavy Duty on application
ST-2-3000	3,000 Litres	2620	885	2720	450	500	Light Duty 250mm Heavy Duty on application