

PACKAGED SEWERAGE PUMPING STATIONS

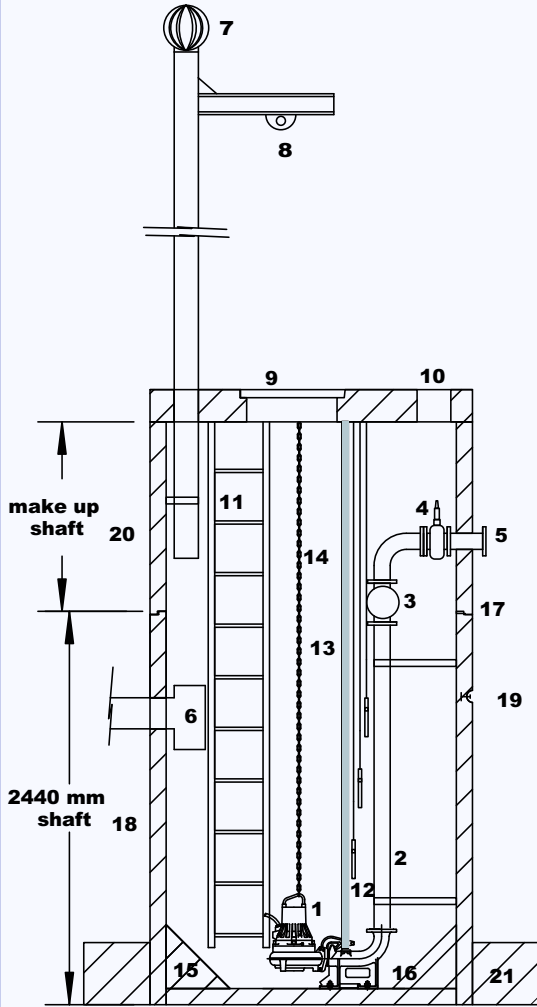

1	FLYGT PUMP
2	DISCHARGE / RISING MAIN - HDPE ELECTRO FUSION
3	BALL TYPE NON RETRUN VALVE, FLYGT- HDL
4	ISOLATING VALVE
5	FLANGED CONNECTION POINT
6	GRAVITY SEWER MAIN INLET
7	WESTERN ROTARY VENT
8	DAVIT INCORPORATING VENT PIPE
9	ACCES COVERS FOR LADDER AND PUMP
10	ACCES COVER FOR ISOLATING VALVE
11	GALVANISED LADDER
12	START, STOP, AND ALARM LEVEL REGULATORS
13	LIFTING CHAIN GALVANISED GRADE L
14	PUMP GUIDERAILS
15	BENCHING / SLUDGE BATTER
16	STAINLESS STEEL FIXINGS
17	EPOXY SEALED JOINT
18	PUMP CHAMBER SPECIFICATIONS
	MIN WALL THICKNESS 100 MM
	COVER TO REINFORCMENT MIN 40 MM
	CONCRETE - SULPHER RESISTANT CEMENT
	50 MPA @ 28 DAYS
19	SWIFT LIFT' PINS FOR SAFE HANDLING
20	OPTIONAL MAKE UP SHAFTS FROM 300 MM
	T0 2440 MM
21	EXTRA BALLAST TO BE POURED INSITU IF REQUIRED

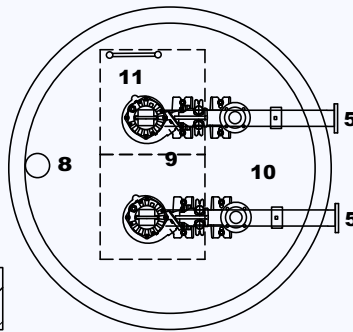

1800mm dia STANDARD 1800DIA PUMP STATION

Launceston Office:
 7 Donalds Avenue
 Prospect, Tasmania 7250
 Phone: 03 63445570
 Fax: 03 63401881

Hobart Office:
 9 Lampton Avenue
 Derwent Park Tasmania 7009
 Phone: 03 62730463
 Fax: 03 62733438